



finder[®]
SWITCH TO THE FUTURE

Filter Fan (24...630)m³/h and Exhaust Filter

7F
SERIES



Drying kilns



Textile machines



Machines
for paper
processing



Machines for
ceramics



Wood-
processing
machines



Panels for
electrical
distribution



Control panels



Forced-air
ventilators





FINDER reserves the right to alter characteristics at any time without notice. FINDER assumes no liability for damage to persons or property, caused as a result of the incorrect use or application of its products.

Filter Fan for electrical cabinets and enclosures 120 V or 230 V AC versions

- Very low acoustic noise
- Minimal depth within enclosure
- Air volume 24, 55 and 100 m³/h (free flow)
- Air volume 14, 40 and 75 m³/h (with Exhaust Filter installed in cabinet)
- Nominal voltage: 120 or 230 V AC (50/60 Hz)
- Time-saving installation and maintenance
- Easily replaceable filter mat
- Filter Fan supplied in Reverse flow mode (7F.21)

NEW 7F.20.8.xxx.1020



- Nominal voltage 120 or 230 V AC
- Air volume 24 m³/h
- Rated power 17 W
- Size 1

NEW 7F.20.8.xxx.2055



- Nominal voltage 120 or 230 V AC
- Air volume 55 m³/h
- Rated power 28 W
- Size 2

NEW 7F.20.8.xxx.3100



- Nominal voltage 120 or 230 V AC
- Air volume 100 m³/h
- Rated power 28 W
- Size 3

For outline drawing see page 14

Fan data

Air volume (free flow)	m ³ /h	24		55		100	
Air volume (with exhaust filter installed)	m ³ /h	14		40		75	
Noise level	dB (A)	27		42		42	
Life time at 40 °C	h	50000		50000		50000	

Electrical data

Nominal voltage (U _N)	V AC (50/60 Hz)	120	230	120	230	120	230
Operating range	AC	(0.8...1.1)U _N		(0.8...1.1)U _N		(0.8...1.1)U _N	
Current consumption	A	0.23	0.1	0.25	0.12	0.25	0.12
Rated power	W	17	17	28	28	28	28

Other data

Housing, cover	Plastics according to UL94 V-0, light grey (RAL 7035)						
Filter mat (included)	G3 according to EN 779, filtering degree (80...90)%						
Filter material	Synthetic fibre with progressive construction, temperature resistant to +100 °C, self extinguishing, Class F1 (DIN 53438)						
Electrical connections	Push-in terminals						
Wire size (mm ²)	min/max	0.7/2.5					
Wire size (AWG)	min/max	18/14					
Ambient temperature range	°C	-15...+55					
Protection class	I						
Protection category according to EN 60529	IP54						
Protection category according to NEMA	Type 12						

Approvals (according to type)



Filter Fan for electrical cabinets and enclosures 120 V or 230 V AC versions

- Very low acoustic noise
- Minimal depth within enclosure
- Air volume 230 and 370 m³/h (free flow)
- Air volume 180 and 250 m³/h (with Exhaust Filter installed in cabinet)
- Nominal voltage: 120 or 230 V AC (50/60 Hz)
- Time-saving installation and maintenance
- Further available versions*:
 - EMC Filter Fan (7F.70) and EMC Exhaust Filter (7F.07)
 - Filter Fan supplied in Reverse flow mode (7F.80)

* Product codes, see pages 8 & 11

7F.50.8.xxx.4230

- Nominal voltage 120 or 230 V AC
- Air volume 230 m³/h
- Rated power 40 W
- Size 4

7F.50.8.xxx.4370

- Nominal voltage 120 or 230 V AC
- Air volume 370 m³/h
- Rated power 70 W
- Size 4

Note:

By reversing the fan motor, the air direction can be changed from "Inlet" Filter Fan mode to "Exhaust" Filter Fan mode** (except for the types 7F.50.8.xxx.4370, 7F.50.8.xxx.5500 and 7F.50.8.xxx.5630).

** Supplied in "Inlet" Filter Fan mode (Standard).

For outline drawing see page 15

Fan data

Air volume (free flow)	m ³ /h	230		370	
Air volume (with exhaust filter installed)	m ³ /h	180		250	
Noise level	dB (A)	53		65	
Life time at 40 °C	h	50000		50000	

Electrical data

Nominal voltage (U _N)	V AC (50/60 Hz)	120	230	120	230
Operating range	AC	(0.8...1.1)U _N		(0.8...1.1)U _N	
Current consumption	A	0.34	0.17	0.8	0.4
Rated power	W	40	40	70	70

Other data

Housing, cover	Plastics according to UL94 V-0, light grey (RAL 7035)				
Filter mat (included)	G3 according to EN 779, filtering degree (80...90)%				
Filter material	Synthetic fibre with progressive construction, temperature resistant to +100 °C, self extinguishing, Class F1 (DIN 53438)				
Electrical connections/wire size	3-pole screw terminals/max. 2.5 mm ²				
Screw torque	Nm	0.8			
Ambient temperature range	°C	-10...+70			
Protection class	I				
Protection category according to EN 60529	IP54				

Approvals (according to type)

Filter Fan for electrical cabinets and enclosures 120 V or 230 V AC versions

- Very low acoustic noise
- Minimal depth within enclosure
- Air volume 500 and 630 m³/h (free flow)
- Air volume 370 and 470 m³/h (with Exhaust Filter installed in cabinet)
- Nominal voltage: 120 or 230 V AC (50/60 Hz)
- Time-saving installation and maintenance
- Further available versions*:
 - EMC Filter Fan (7F.70) and EMC Exhaust Filter (7F.07)
 - Filter Fan supplied in Reverse flow mode (7F.80)

* Product codes, see pages 8 & 11

Note:

By reversing the fan motor, the air direction can be changed from "Inlet" Filter Fan mode to "Exhaust" Filter Fan mode** (except for the types 7F.50.8.xxx.4370, 7F.50.8.xxx.5500 and 7F.50.8.xxx.5630).

** Supplied in "Inlet" Filter Fan mode (Standard).

For outline drawing see page 15

7F.50.8.xxx.5500



- Nominal voltage 120 or 230 V AC
- Air volume 500 m³/h
- Rated power 70 W
- Size 5

7F.50.8.xxx.5630



- Nominal voltage 120 or 230 V AC
- Air volume 630 m³/h
- Rated power 130 W
- Size 5

Fan data

Air volume (free flow)	m ³ /h	500	630
Air volume (with exhaust filter installed)	m ³ /h	370	470
Noise level	dB (A)	65	72
Life time at 40 °C	h	50000	50000

Electrical data

Nominal voltage (U _N)	V AC (50/60 Hz)	120	230	120	230
Operating range	AC	(0.8...1.1)U _N		(0.8...1.1)U _N	
Current consumption	A	0.8	0.4	1.10	0.55
Rated power	W	70	70	130	130

Other data

Housing, cover	Plastics according to UL94 V-0, light grey (RAL 7035)			
Filter mat (included)	G3 according to EN 779, filtering degree (80...90)%			
Filter material	Synthetic fibre with progressive construction, temperature resistant to +100 °C, self extinguishing, Class F1 (DIN 53438)			
Electrical connections/wire size	screw terminals / max. 2.5 mm ²			
Screw torque	Nm	0.8		
Ambient temperature range	°C	-10...+70		
Protection class	I			
Protection category according to EN 60529	IP54			

Approvals (according to type)



Filter Fan for electrical cabinets and enclosures 24 V DC versions

- Very low acoustic noise
- Minimal depth within enclosure
- Air volume 24, 55 and 100 m³/h (free flow)
- Air volume 14, 40 and 75 m³/h (with Exhaust Filter installed in cabinet)
- Nominal voltage: 24 V DC
- Time-saving installation and maintenance
- Easily replaceable filter mat
- Filter Fan supplied in Reverse flow mode (7F.21)

NEW 7F.20.9.024.1020

- Nominal voltage 24 V DC
- Air volume 24 m³/h
- Rated power 3.6 W
- Size 1

NEW 7F.20.9.024.2055

- Nominal voltage 24 V DC
- Air volume 55 m³/h
- Rated power 7 W
- Size 2

NEW 7F.20.9.024.3100

- Nominal voltage 24 V DC
- Air volume 100 m³/h
- Rated power 7 W
- Size 3

For outline drawing see page 14

Fan data

Air volume (free flow)	m ³ /h	24	55	100
Air volume (with exhaust filter installed)	m ³ /h	14	40	75
Noise level	dB (A)	37.5	46	45
Life time at 40 °C	h	50000	50000	50000

Electrical data

Nominal voltage (U _N)	V DC	24	24	24
Operating range	DC	(0.8...1.1)U _N	(0.8...1.1)U _N	(0.8...1.1)U _N
Current consumption	A	0.15	0.32	0.32
Rated power	W	3.6	7	7

Other data

Housing, cover	Plastics according to UL94 V-0, light grey (RAL 7035)			
Filter mat (included)	G3 according to EN 779, filtering degree (80...90)%			
Filter material	Synthetic fibre with progressive construction, temperature resistant to 100 °C, self extinguishing, Class F1 (DIN 53438)			
Electrical connections	Push-in terminals			
Wire size (mm ²)	min/max	0.7/2.5		
Wire size (AWG)	min/max	18/14		
Ambient temperature range	°C	-15...+55		
Protection class	I			
Protection category according to EN 60529	IP54			
Protection category according to NEMA	Type 12			

Approvals (according to type)

Filter Fan for electrical cabinets and enclosures 24 V DC versions

- Very low acoustic noise
- Minimal depth within enclosure
- Air volume 230 m³/h (free flow)
- Air volume 180 m³/h (with Exhaust Filter installed in cabinet)
- Nominal voltage: 24 V DC
- Time-saving installation and maintenance
- Filter Fan supplied in Reverse flow mode (7F.80)

* Product codes, see pages 8 & 11

7F.50.9.024.4230



- Nominal voltage 24 V DC
- Air volume 230 m³/h
- Rated power 26 W
- Size 4

Note:

By reversing the fan motor, the air direction can be changed from "Inlet" Filter Fan mode to "Exhaust" Filter Fan mode** (except for the types 7F.50.8.xxx.4370, 7F.50.8.xxx.5500 and 7F.50.8.xxx.5630).

** Supplied in "Inlet" Filter Fan mode (Standard).

For outline drawing see page 15

Fan data		
Air volume (free flow)	m ³ /h	230
Air volume (with exhaust filter installed)	m ³ /h	180
Noise level	dB (A)	61
Life time at 40 °C	h	50000
Electrical data		
Nominal voltage (U _N)	V DC	24
Operating range	DC	(0.8...1.1)U _N
Current consumption	A	1.08
Rated power	W	26
Other data		
Housing, cover		Plastics according to UL94 V-0, light grey (RAL 7035)
Filter mat (included)		G3 according to EN 779, filtering degree (80...90)%
Filter material		Synthetic fibre with progressive construction, temperature resistant to 100 °C, self extinguishing, Class F1 (DIN 53438)
Electrical connections/wire size		screw terminals / max. 2.5 mm ²
Screw torque	Nm	0.8
Ambient temperature range	°C	-10...+70
Protection class		I
Protection category according to EN 60529		IP54
Approvals (according to type)		CE EAC cRU[®] US

Ordering information

Example: Series 7F, Filter Fan for mounting in sidewalls, nominal voltage 230 V AC, size 1, air volume 24 m³/h.

7 F . 2 0 . 8 . 2 3 0 . 1 0 2 0

Series

Type

20 = Filter Fan - for indoor use
21 = Reverse flow Filter Fan - for indoor use
50 = Filter Fan - for indoor use
70 = EMC Filter Fan - for indoor use
80 = Reverse flow Filter Fan - for indoor use

Supply version

8 = AC (50/60 Hz)
9 = DC

Operating voltage

024 = 24 V DC
120 = 120 V AC
230 = 230 V AC

Enclosure cut-out

1 = Size 1 (92^{+0.5} x 92^{+0.5}) mm
2 = Size 2 (125^{+1.0} x 125^{+1.0}) mm
3 = Size 3 (177^{+1.0} x 177^{+1.0}) mm
4 = Size 4 (224^{+1.0} x 224^{+1.0}) mm
5 = Size 5 (291^{+1.0} x 291^{+1.0}) mm

Air volume (free flow)

020 = 24 m³/h
055 = 55 m³/h
100 = 100 m³/h
230 = 230 m³/h
370 = 370 m³/h
500 = 500 m³/h
630 = 630 m³/h

Filter Fans - All versions

Standard versions	EMC versions	Reverse flow versions	
7F.20.8.120.1020	—	7F.21.8.120.1020	Filter Fan, Size 1
7F.20.8.120.2055	—	7F.21.8.120.2055	Filter Fan, Size 2
7F.20.8.120.3100	—	7F.21.8.120.3100	Filter Fan, Size 3
7F.50.8.120.4230	—	7F.80.8.120.4230	Filter Fan, Size 4
7F.50.8.120.4370	—	7F.80.8.120.4370	Filter Fan, Size 4
7F.50.8.120.5500	—	7F.80.8.120.5500	Filter Fan, Size 5
7F.50.8.120.5630	—	—	Filter Fan, Size 5
7F.20.8.230.1020	—	7F.21.8.230.1020	Filter Fan, Size 1
7F.20.8.230.2055	—	7F.21.8.230.2055	Filter Fan, Size 2
7F.20.8.230.3100	—	7F.21.8.230.3100	Filter Fan, Size 3
7F.50.8.230.4230	7F.70.8.230.4230	7F.80.8.230.4230	Filter Fan, Size 4
7F.50.8.230.4370	7F.70.8.230.4370	7F.80.8.230.4370	Filter Fan, Size 4
7F.50.8.230.5500	7F.70.8.230.5500	7F.80.8.230.5500	Filter Fan, Size 5
7F.50.8.230.5630	7F.70.8.230.5630	—	Filter Fan, Size 5
7F.20.9.024.1020	—	7F.21.9.024.1020	Filter Fan, Size 1
7F.20.9.024.2055	—	7F.21.9.024.2055	Filter Fan, Size 2
7F.20.9.024.3100	—	7F.21.9.024.3100	Filter Fan, Size 3
7F.50.9.024.4230	7F.70.9.024.4230	7F.80.9.024.4230	Filter Fan, Size 4

Note:

The technical features (air volume, dimensions and electrical parameters) for the Standard Filter Fans (7F.20 and 7F.50), the EMC Filter Fans (7F.70) and the Reverse flow versions (7F.21 and 7F.80) - are exactly the same.

7F.50.8.120.5630 has no UL approval. Other versions on request.

Exhaust Filter

The size of the Exhaust Filter should match the size of the Filter Fan to achieve the best ventilation within the cabinet

- Minimum depth within enclosure
- Time-saving installation and maintenance
- Easily replaceable filter mat

NEW

7F.02.0.000.1000



- For Filter Fans 7F.20.x.xxx.1020
- Size 1

NEW

7F.02.0.000.2000



- For Filter Fans 7F.20.x.xxx.2055
- Size 2

NEW

7F.02.0.000.3000



- For Filter Fans 7F.20.x.xxx.3100
- Size 3

For outline drawing see page 14

Other data

Housing, cover	Plastics according to UL94 V-0, light grey (RAL 7035)
Filter mat (included)	G3 according to EN 779, filtering degree (80...90)%
Filter material	Synthetic fibre with progressive construction, temperature resistant to +100 °C, self extinguishing, Class F1 (DIN 53438)
Protection category according to EN 60529	IP54
Protection category according to NEMA	Type 12
Approvals (according to type)	CE EAC cRU[®] US

G

Exhaust Filter

The size of the Exhaust Filter should match the size of the Filter Fan to achieve the best ventilation within the cabinet

- Minimum depth within enclosure
- Time-saving installation and maintenance
- Further available versions*:
- EMC Exhaust Filters (7F.07)

* Product codes, see page 11

7F.05.0.000.4000



- For Filter Fans
7F.50.x.xxx.4230 or
7F.50.8.xxx.4370
- Size 4

7F.05.0.000.5000



- For Filter Fans
7F.50.8.xxx.5500 or
7F.50.8.xxx.5630
- Size 5

For outline drawing see page 15

Other data

Housing, cover	Plastics according to UL94 V-0, light grey (RAL 7035)
Filter mat (included)	G3 according to EN 779, filtering degree (80...90)%
Filter material	Synthetic fibre with progressive construction, temperature resistant to +100 °C, self extinguishing, Class F1 (DIN 53438)

Protection category according to EN 60529 IP54

Approvals (according to type)



Ordering information

Example: Series 7F, Exhaust Filter for mounting in sidewalls, size 1.

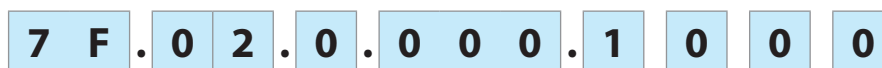

Series

Type

- 02 = Exhaust Filter - for indoor use
- 05 = Exhaust Filter - for indoor use
- 07 = EMC Exhaust Filter - for indoor use

Supply and operating voltage

0 = Not applicable for Exhaust Filter

Operating voltage

000 = Not applicable for Exhaust Filter

Enclosure cut-out

- 1000 = Size 1 ($92^{+0.5} \times 92^{+0.5}$) mm
- 2000 = Size 2 ($125^{+1.0} \times 125^{+1.0}$) mm
- 3000 = Size 3 ($177^{+1.0} \times 177^{+1.0}$) mm
- 4000 = Size 4 ($224^{+1.0} \times 224^{+1.0}$) mm
- 5000 = Size 5 ($291^{+1.0} \times 291^{+1.0}$) mm

Exhaust Filter - All versions

Standard-versions	EMC - versions	
7F.02.0.000.1000	—	Exhaust Filter, Size 1
7F.02.0.000.2000	—	Exhaust Filter, Size 2
7F.02.0.000.3000	—	Exhaust Filter, Size 3
7F.05.0.000.4000	7F.07.0.000.4000	Exhaust Filter, Size 4
7F.05.0.000.5000	7F.07.0.000.5000	Exhaust Filter, Size 5

Components

Standard-Filter Fan	Standard-Exhaust Filter	EMC-Filter Fan	EMC-Exhaust Filter	Filter mat	Size
7F.20.8.xxx.1020	7F.02.0.000.1000	—	—	07F.15	1
7F.20.8.xxx.2055	7F.02.0.000.2000	—	—	07F.25	2
7F.20.8.xxx.3100	7F.02.0.000.3000	—	—	07F.35	3
7F.50.8.xxx.4230	7F.05.0.000.4000	7F.70.8.230.4230	7F.07.0.000.4000	07F.45	4
7F.50.8.xxx.4370	7F.05.0.000.4000	7F.70.8.230.4370	7F.07.0.000.4000	07F.45	4
7F.50.8.xxx.5500	7F.05.0.000.5000	7F.70.8.230.5500	7F.07.0.000.5000	07F.55	5
7F.50.8.xxx.5630	7F.05.0.000.5000	7F.70.8.230.5630	7F.07.0.000.5000	07F.55	5
7F.20.9.024.1020	7F.02.0.000.1000	—	—	07F.15	1
7F.20.9.024.2055	7F.02.0.000.2000	—	—	07F.25	2
7F.20.9.024.3100	7F.02.0.000.3000	—	—	07F.35	3
7F.50.9.024.4230	7F.05.0.000.4000	7F.70.9.024.4230	7F.07.0.000.4000	07F.45	4

Spare Filter mats	07F.15	07F.25	07F.35	07F.45	07F.55
Protection category	IP54				

Accessories



07F.80

Pressure compensation device, for pressure compensation in closed cabinets or enclosures	07F.80
Air interface area	cm ² 7
Mounting	PG 29 thread with union nut
Torque	Nm 5 (max. 10)
Material	plastic according to UL94-V0
Dimensions (diameter/depth)	mm 65.5/30.5
Mounting position	upper part of cabinet sidewalls
Ambient temperature	°C -45...+70
Protection category	IP55

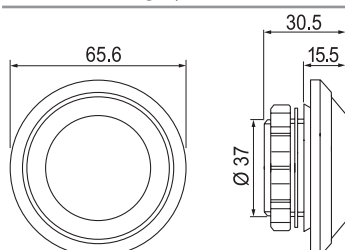

Unit package contains 2 pressure compensation devices

Mounting instructions for Filter Fans

Mounting arrangement of Filter Fans and Exhaust Filter

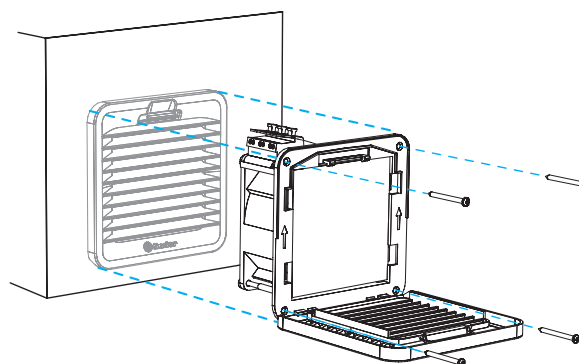
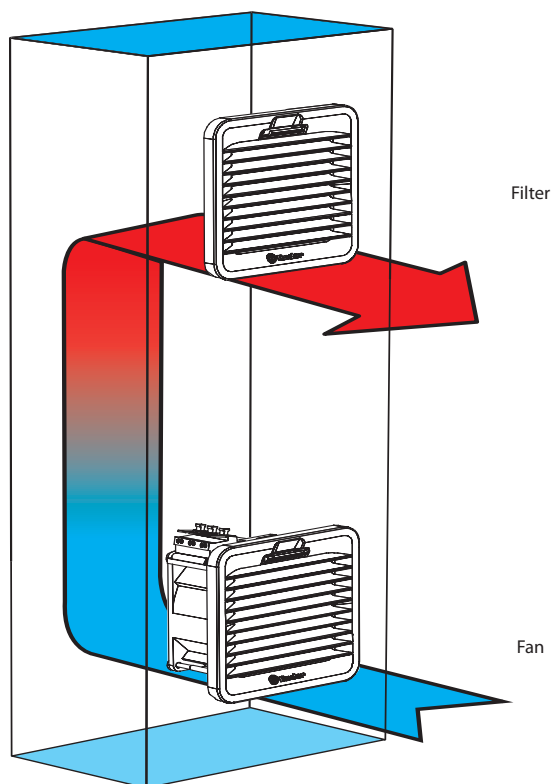

The installation with the only clips is optimized for 1.5 mm thick sheets; it is also possible with thicknesses from 1 to 2.5 mm. Fixing with screws (supplied) is recommended. Tightening torque 0.3 Nm.

G Replacement of Filter mat (Type 7F.20)

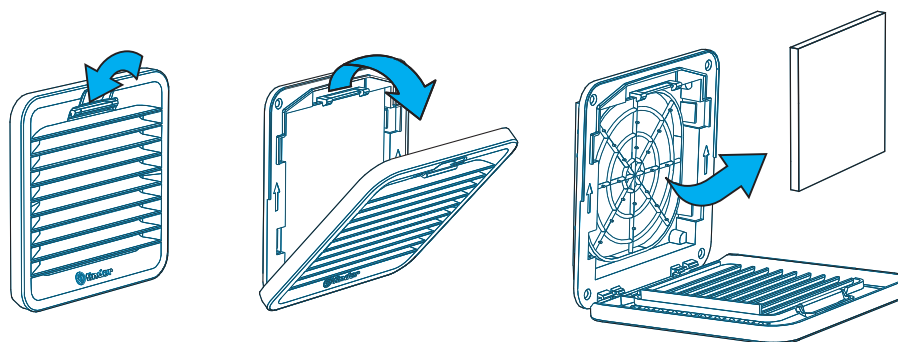

Drilling template and mounting cut-outs for Filter Fans and Exhaust Filter

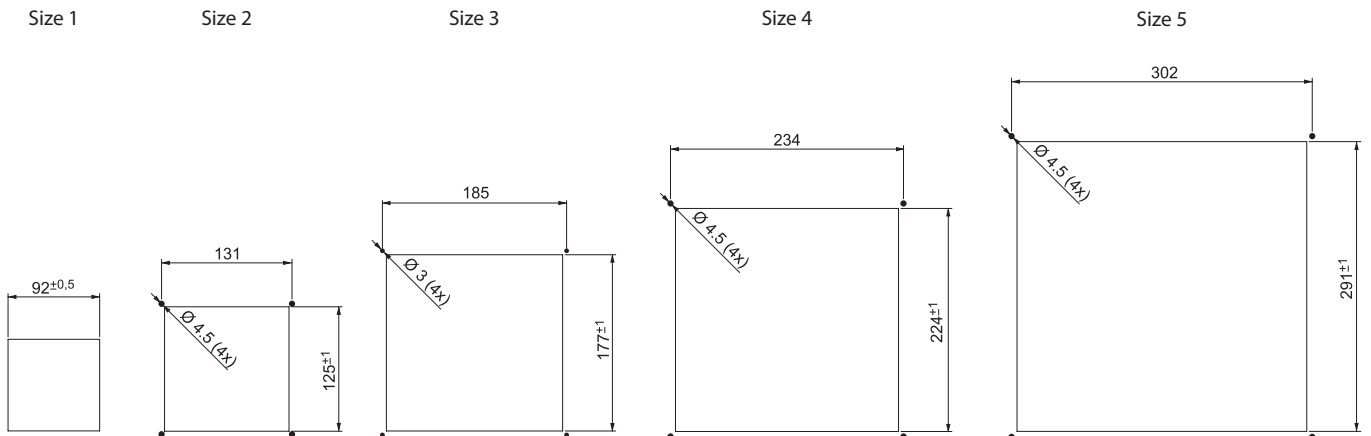

Mounting and maintenance

1. Make the panel cut-out according to the size of the Filter Fan or Exhaust Filter in the sidewall of the cabinet as appropriate.
A template of the panel cut-out is included in the packaging of the Filter Fan or Exhaust Filter.
2. Make the electrical connection.
3. Mount by simply snapping the side-located lugs on the Filter Fan or Exhaust Filter into the panel cut-out (without using screws for sidewall thickness of 1.2...2.4 mm).
At other thickness it is recommended to mount the Filter Fan by the screws supplied (for size 1, the template shows the mounting cut-out only).
4. When screws are needed for the mounting, remove the plastic cover and fix the Filter Fan with the 4 screws supplied.
Then insert the filter mat and snap the plastic cover to the mounting frame.
5. During maintenance or when replacing the filter mat remove the plastic cover, replace the filter mat and snap on the plastic cover.

Outline drawings

Type 7F.20.x.xxx.1020

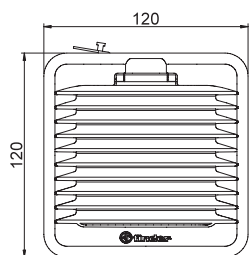

AC version

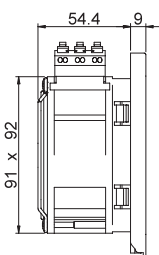

DC version

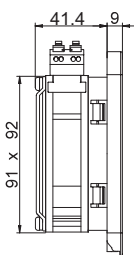

Type 7F.02.0.000.1000

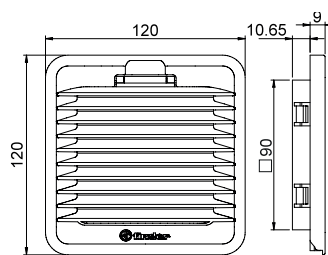

Type 7F.20.x.xxx.2055

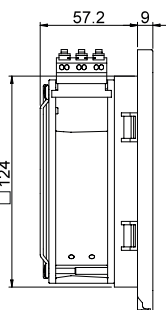
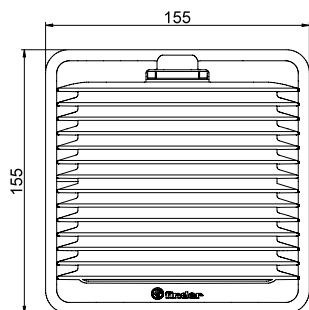

Type 7F.02.0.000.2000

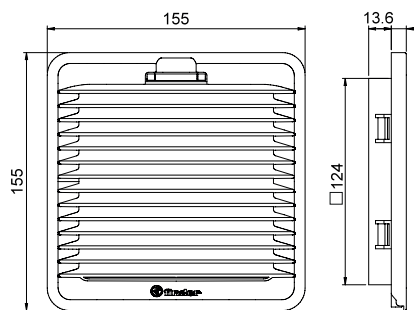

Type 7F.20.x.xxx.3100

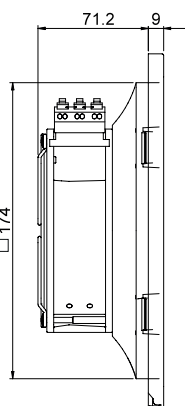
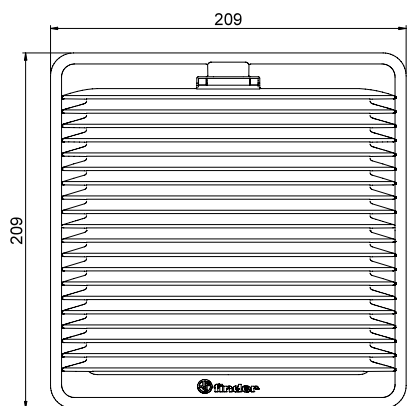

Type 7F.02.0.000.3000

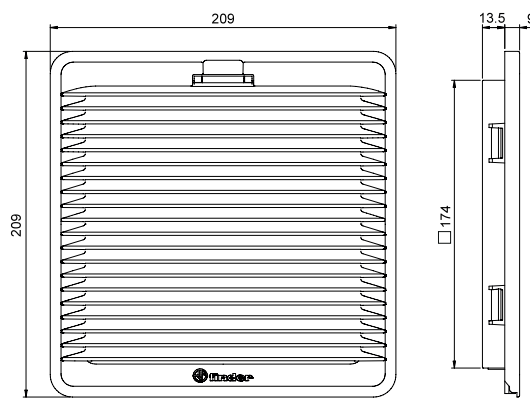

G

Outline drawings

Type 7F.50.x.xxx.4230

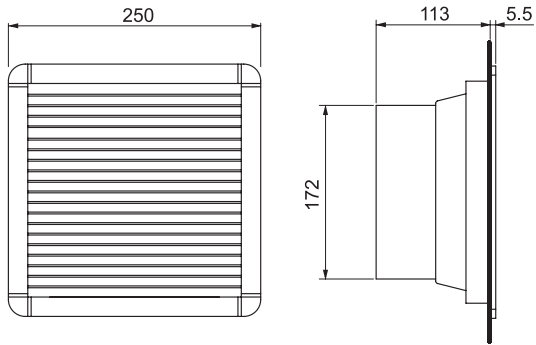

Type 7F.05.0.000.4000

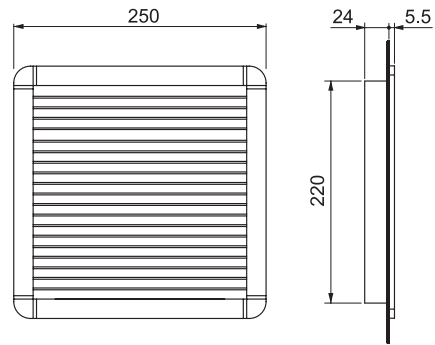

Type 7F.50.x.xxx.4370

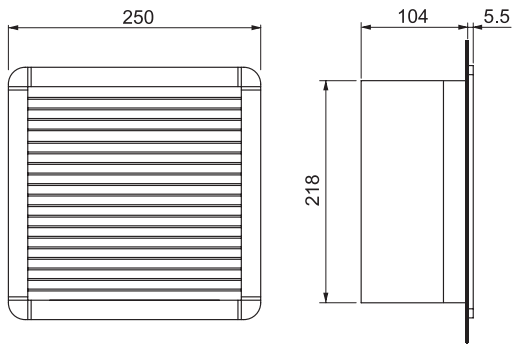

Type 7F.05.0.000.4000

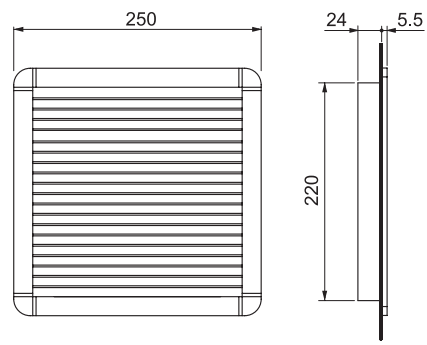

Type 7F.50.x.xxx.5500

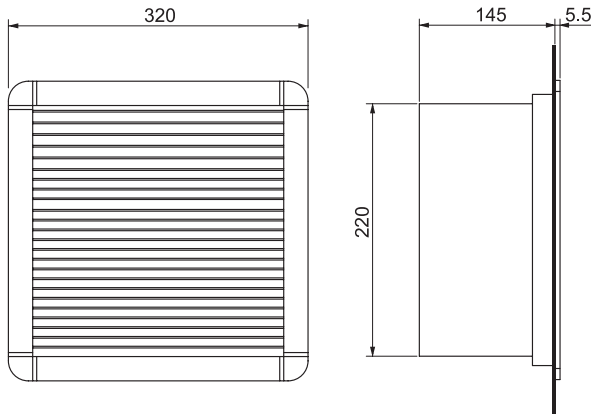

Type 7F.05.0.000.5000

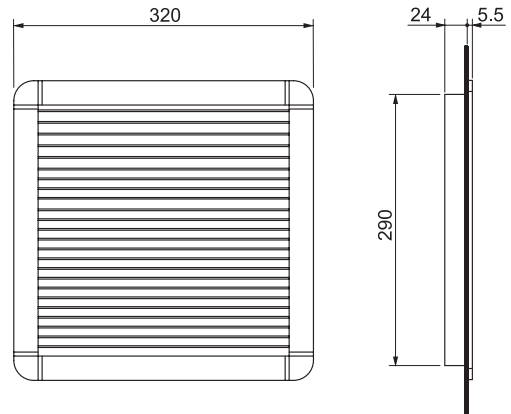

Type 7F.50.x.xxx.5630

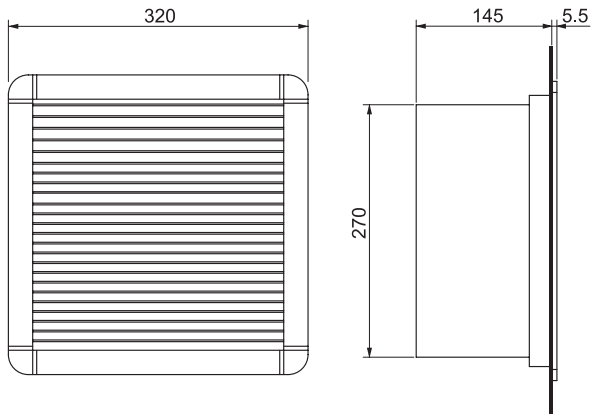

Type 7F.05.0.000.5000

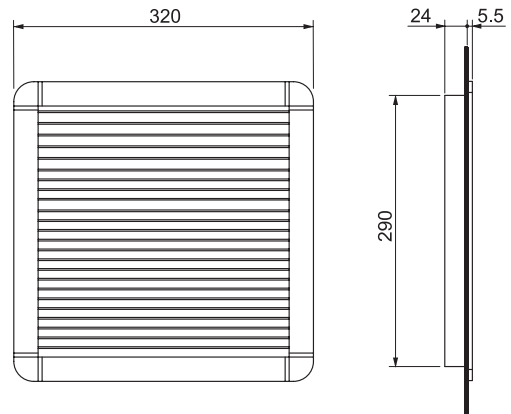

Fan selection

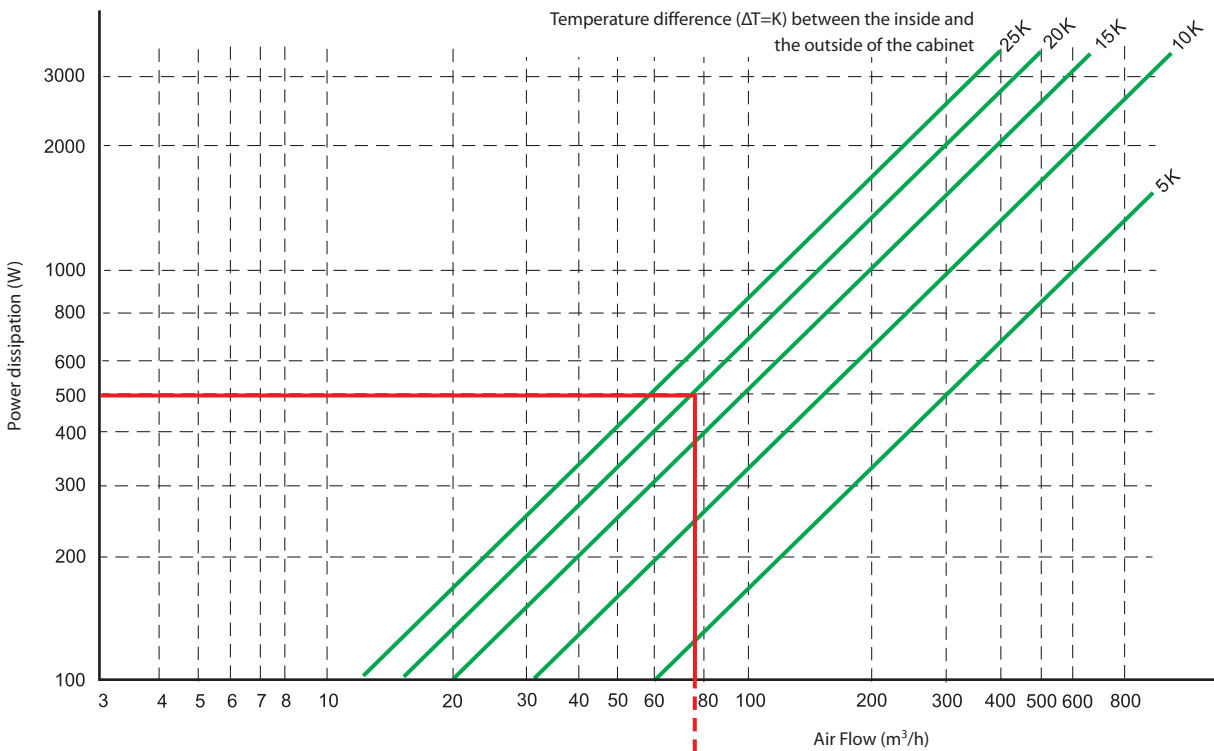

G

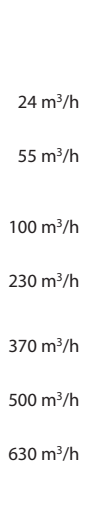

Example

First, estimate the power dissipated within the cabinet. Then calculate the maximum difference between the internal and external temperature (green lines) by considering the difference between the maximum permitted internal temperature (as dictated by the temperature rating of the enclosed components, or specification) and the maximum temperature expected outside the cabinet.

The projection onto the X axis, of the intersection between the power (watts) and the appropriate green line, corresponds to the air flow rate in m³/h required to meet the maximum internal temperature limit. Extending this line vertically to intersect with the blue horizontal lines, indicates the most appropriate model of 7F fan to be fitted to the cabinet to provide the requisite air flow.

The example above considers a cabinet with an internal thermal power dissipation of 500 W, and assumes the maximum temperature difference between the inside and the outside of the cabinet to be 20K. The required air flow can be seen to be a little less than 80 m³/h.

It is suggested that this is increased by 10% to allow for the affects of a dirty filter.

And so, it can be seen that models of the 7F with 100 m³/h flow rate will provide the proper dissipation of heat under these circumstances.

Application notes

Filter Fan

The ball-bearing axial fan housing is made of aluminium and the rotor is made of plastic or metal (depending on the type).

Filter classes

Within EN 779 are specified 9 filter classes, categorised into 4 coarse dust filters and 5 fine dust filters.

The coarse dust filters G1 - G4 are able to filter particles > 10 µm and the fine dust filters G5 - G9 are able to filter particles from (1...10)µm.

Filter classes	Example of particle	Particle size
G1 - G4 (EU1 - EU4)	Textile fibers, hair, sand, pollen, spores, insects, cement dust	> 10 µm
G5 - G9 (EU5 - EU9)	Pollen, spores, cement dust, tobacco smoke, oil smoke, soot	(1...10)µm

Filtering degree (Am)

The degree of filtering (Am) is the percentages of dust, by weight, that is caught and retained by the filter.

Filter mats

The quality of these filter mats has been independently tested, according to EN 779 and branded after passing the test.

The filter mats are to filter class G3 and have an average filtering degree of (80...90)%.

Filter material

The filter material consists of a synthetic fiber with progressive construction which is moisture-resistant to 100% RH and temperature resistant to +100 °C.

According to the strict requirements of fire class F1, DIN 53438, these filter mats are self-extinguishing.

Progressive construction at filter mats

The individual fibers of these filter mats are bonded by a special process to provide a progressive construction where the fiber size and spacing varies through the thickness of the filter mat.

This means that coarse dust particles are caught early and fine dust later through the thickness of the mat. In this way the entire depth of the filter mat is used.

Flammability class of the housing and the cover

The plastic materials used comply with flammability class V-0, according to UL94.

EMC Filter Fans and EMC Exhaust Filters

The plastic mounting frame of the EMC Filter Fans (7F.70) and EMC Exhaust Filters (7F.07) are sprayed with a conductive (metallic) paint.

The gasket located on the mounting frame, for sealing the Filter Fan or Exhaust Filter in the cabinet is also metalised.

In addition; located at the EMC Filter Fan between the metalized mounting frame and the filter mat, is a metal grid.

Therefore, between the metal parts of the Filter Fan and the metal cabinet, there is a conductive connection.

Filter Fan in "reverse flow" version

As supplied, the standard Filter Fan is in "Draw-In"- mode, which means that cool air is filtered and drawn into the cabinet. In some cases it may be required that the warm air is blown out of the cabinet.

In which case it is possible to get Filter Fans in "Exhaust Filter" mode version (7F.80).

Mounting of the pressure compensation device

In sealed cabinets and enclosures the internal pressure can vary due to changes in temperature. The pressure compensation device (07F.80) will relieve this internal/external pressure differential whilst maintaining a high level of protection - preventing the ingress of dust and moisture into the cabinet or the enclosure. The pressure compensation device is approved for use in cabinets and enclosures according to DIN EN 62208.

Drill a hole Ø 37^{+1.0} mm in the housing wall and fix the pressure compensation device with the accompanying nut. It is important to ensure that the sealing ring is located on the outside. To ensure optimum pressure balance, it is recommended to fit 2 pressure compensation devices at the upper sides of the cabinet or enclosure.

